

END VIEW

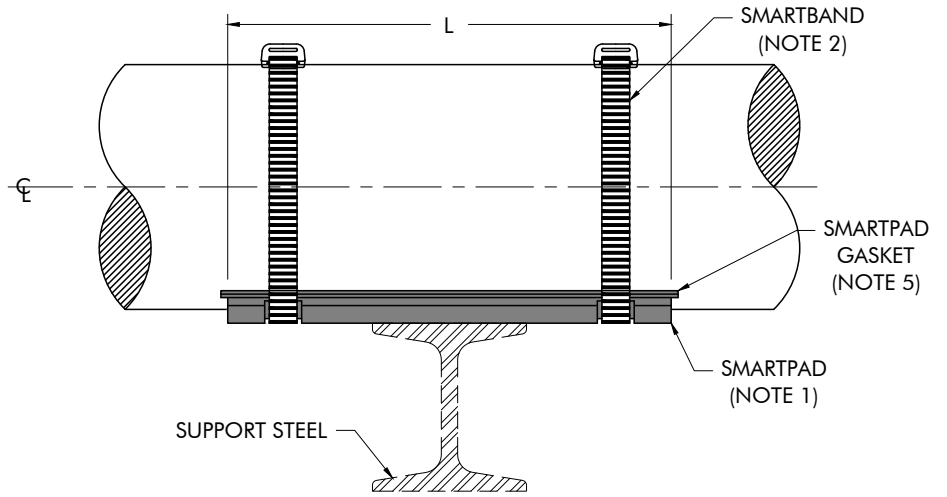

SIDE VIEW

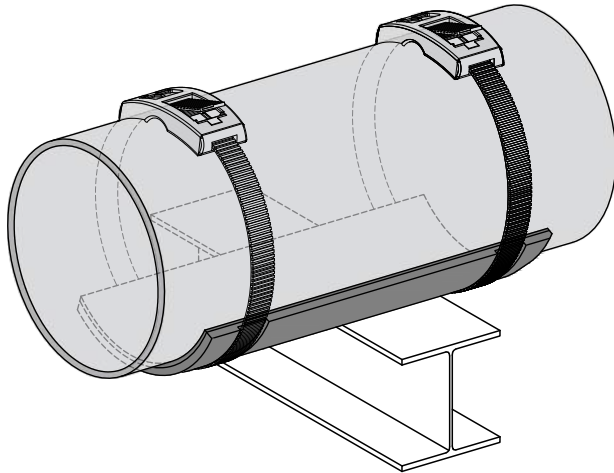

**ORDERING INFORMATION:**

**PART NUMBER:** SP- LT - NPS - T - A - L

**EXAMPLE:** SP- LT - 6" - 1/2" - 60° - 12"  
 [12.7mm] [304.8mm]

SP SMARTPAD  
 LT NON-BEVELED EDGES  
 6" NOMINAL PIPE SIZE  
 [12.7mm] 1/2" THICKNESS  
 60° PIPE COVERAGE ANGLE  
 [304.8mm] 12" LENGTH

PIPE SIZE (NPS)	PAD THK. "T" (NOTE 3)	STANDARD ANGLE "A" (NOTE 3)	STANDARD LENGTH "L" (NOTE 3)
	IN. [mm]		IN. [mm]
3/4" - 4"	1/2" [12.7mm]	90°	12" [304.8mm]
6" - 10"	1/2" [12.7mm]	60°	12" [304.8mm]
12" - 16"	1/2" [12.7mm]	45°	12" [304.8mm]
18" - 24"	1/2" [12.7mm]	45°	18" [457.2mm]

OTHER SIZES AVAILABLE, CONTACT COGBILL FOR MORE INFORMATION

**NOTES:**

1. RedLineIPS SmartPad is made from vinyl ester resin material, as manufactured by Cogbill Construction.
2. SmartPad is secured to the pipe using the RedLineIPS composite banding system (SmartBand) as per the SmartPadSystem official installation procedure.
3. Various thicknesses, angles of coverage, and lengths are based on the specific design parameters of the piping system and are available upon request.
4. Operating temperature range is -60°F (-51°C) to 400°F (204°C).
5. RedLineIPS SmartPads include a pre-installed RedLineIPS Gasket for sealing it to the pipe, offering a NEMA 4 watertight seal to prevent corrosion.
6. 50,000 lbs (22,680 kg) compressive strength.

REV	DESCRIPTION	BY	CHK.	DATE	PIPING STANDARD DETAILS	 2325 S MAIN ST. VIDOR, TX 77662 409-768-1419 www.SmartPadSystem.com Info@SmartPadSystem.com
0	ISSUED FOR CONSTRUCTION	GT	HA	11/20/2019		
A	ISSUED FOR APPROVAL	GT	HA	7/10/2019		